

Beam-A-Temp™ Wide Range Mini-Infrared Thermometer

Measures non-contact surface temperature up to 1200°F/650°C



Temperature range from
-58 to 1200°F (-50 to 650°C)

Design Features

- * 12:1 distance to target ratio.
- * Compact thermometer measures temperature from -58 to 1200°F (-50 to 650°C) with 0.1° resolution up to 999.9°.
- * Adjustable High/Low setpoints with audible alarm alerts user when temperature exceeds the programmed setpoints.
- * Adjustable emissivity for better accuracy on different surfaces.
- * Built-in laser pointing identifies target area.
- * Backlighting illuminates display for taking readings in low light areas.
- * Data Hold and Min/Max.
- * Over-range indicator.
- * Complete with 9V battery and pouch case.

Specifications

Temperature Range: -58 to 1200°F (-50 to 650°C)
Basic Accuracy: ±(1% of reading + 2°F/1°C)
Maximum Resolution: 0.1°F/°C; 1°F/°C
Emissivity: 0.10 to 1.00 adjustable
Repeatability: ±0.5% or ±1.8°F/°C
Field of View: 12:1
Dimensions: 3.2 × 1.6 × 6.3" (82 × 42 × 160 mm)
Weight: 6.4 oz. (180g)

Agency Approval: 

Applications

- ➔ Measure the surface temperature of objects difficult to reach or unsafe to touch.
- ➔ Scan for hot spots on motors, electrical panels, electrical circuits and other equipment.
- ➔ Used extensively in processes where glass, iron and steel, non-ferrous materials, and minerals must be monitored.

Ordering Information

Part Number **REB30012** Wide Range Mini-IR Thermometer
Part Number **REB32012** Wide Range Mini-IR Thermometer
with NIST Certificate

Standard lead time is stock to 3 weeks.

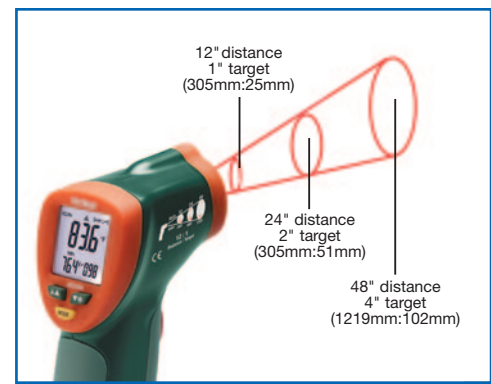

12:1 distance to target ratio

 **WARNING:** Cancer and Reproductive Harm - www.P65Warnings.ca.gov.

Beam-A-Temp™ Wide Range Infrared Thermometer with Type K input

Measures both non-contact and contact temperature with type K thermocouple input



Memory stores up to 20 readings!

REB30020 with Type K temperature probe (included range -4 to 482°F/-20 to 250°C) for contact temperature measurements. Compatible with other Type K thermometers with sub-miniature connector for higher temperature measurements up to 2498°F (1370°C).

Design Features

- * Wide temperature range for IR temperature and type K thermocouple instruments.
- * Automatic emissivity adjustment (for temperatures 212°F or higher).
- * Memory stores up to 20 readings.
- * Large LCD display with bright backlight for easy-to-read measurements and programming parameters.
- * Laser pointer provides better aim and accuracy.
- * Auto-hold activates when the measurement trigger is released.
- * Adjustable high/low alarm alerts user visually and audibly when temperature exceeds programmed limits.
- * MAX/MIN/AVG/DIF features display highest, lowest, average, and MAX minus MIN values.
- * Data Hold, Auto Power Off, and low battery indication.
- * Switches built into handle allow for °C/°F display selection, auto power off defeat, and alarm on/off control.
- * Complete with 9V battery, type K thermocouple sensor (-4 to 482°F / -20 to 250°C), and carrying case.
- * 1-year warranty.

Specifications

Display Counts: . . . 4000 count backlit display
Range: Infrared: -58 to 1472°F (-50 to 800°C)
 Type K: -58 to 2498°F (-50 to 1370°C)
Basic Accuracy: . . Infrared: ±2% of reading or ±4°F/2°C
 Type K: (±1.5% of reading +2°F/1°C)

Maximum Resolution: 0.1°F/°C
Emissivity: Adjustable 0.10 to 1.00
Field of View: 13:1 distance to target ratio
Dimensions: 3.2 × 1.6 × 6.3" (82 × 42 × 160 mm)
Weight: 6.4 oz. (180g)

Agency Approval:

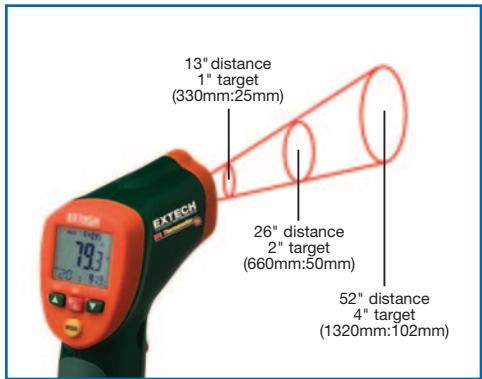

13:1 distance to target ratio

WARNING: Cancer and Reproductive Harm - www.P65Warnings.ca.gov.

Ordering Information

Part Number **REB30020** Wide Range IR Thermometer + Type K
 Part Number **REB32020** Wide Range IR Thermometer with NIST Certificate
Standard lead time is stock to 3 weeks.

Beam-A-Temp™ High Temperature Infrared Thermometer

Measures surface temperature up to 1400°F/760°C

Temperature range from
-58 to 1400°F (-50 to 760°C)!



Design Features

- * Wide temperature range from -58 to 1400°F (-50 to 760°C).
- * High 16:1 distance to target ratio measures smaller surface areas at greater distances.
- * Adjustable emissivity from 0.1 to 1.00 increases measurement accuracy for different surfaces.
- * Adjustable High/Low setpoints alarm with audible alarm alerts user when temperature exceeds the programmed setpoints.
- * Data Hold, MAX/MIN/AVG plus differential between MAX - MIN.
- * Built-in laser identifies target area.
- * Backlit LCD display.
- * High resolution of 0.1° up to 199.9°.
- * Auto power off.
- * Complete with 9V battery and hard carrying case.
- * 3-year warranty.

Specifications

Range: -58 to 1400°F (-50 to 760°C)
Basic Accuracy: ±2% of reading or 4°F/2°C <932°F (500°C); ±(2.5% of reading +5°) >932°F (500°C)
Maximum Resolution: 0.1°F/°C
Emissivity: 0.1 to 1.00 Adjustable
Field of View (Distance to Target): . . 16:1
Dimensions: 3.9 × 2.2 × 9" (100 × 56 × 230 mm)
Weight: 10.2 oz. (290g)

Agency Approval: 

Applications

- Measure the surface temperature of objects difficult to reach or unsafe to touch.
- Scan for hot spots on motors, electrical panels, electrical circuits and other equipment.
- Used extensively in processes where glass, iron and steel, non-ferrous materials, and minerals must be monitored.

Ordering Information

Part Number **REB30030** High Temperature IR Thermometer
Part Number **REB32030** High Temperature IR Thermometer with NIST Certificate

Standard lead time is stock to 3 weeks.

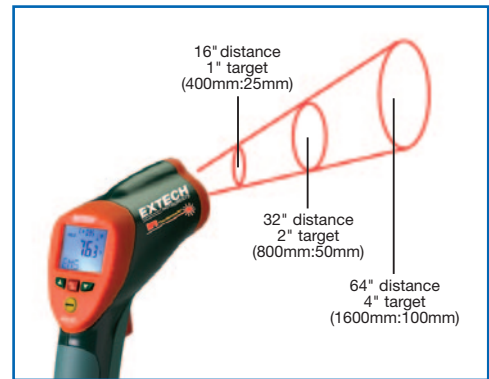

16:1 distance to target ratio

 **WARNING:** Cancer and Reproductive Harm - www.P65Warnings.ca.gov.

Beam-A-Temp™ Portable Infrared Thermometer

Measures up to 1832°F/1000°C with 50:1 distance to target ratio

*Temperature range from
-58 to 1832°F (-50 to 1000°C)!*



Design Features

- * Built-in laser identifies target area.
- * High and low alarms.
- * Adjustable emissivity increases measurement accuracy for different surfaces.
- * Adjustable High/Low setpoints alarm with audible alarm alerts user when temperature exceeds the programmed setpoints.
- * MAX/MIN/AVG plus differential between MAX – MIN.
- * Backlighting illuminates display for taking measurements at night or in areas with low background light levels.
- * High resolution of 0.1° up to 199.9°.
- * Automatic Data Hold when trigger released.
- * Auto power off.
- * Wide temperature range from -58 to 1832°F (-50 to 1000°C).
- * High 50:1 distance to target ratio measures smaller surface areas at greater distances.
- * Complete with 9V battery and carrying case.
- * 3-year warranty.

Specifications

Range:	-58 to 1832°F (-50 to 1000°C)
Basic Accuracy:	±2% of reading or +4°F/2°C
Maximum Resolution:	0.1°F/°C
Emissivity:	Adjustable
Field of View (Distance to Target):	..	50:1
Dimensions:	3.9 × 2.2 × 9" (100 × 56 × 230 mm)
Weight:	10.2 oz. (290g)

Agency Approval:

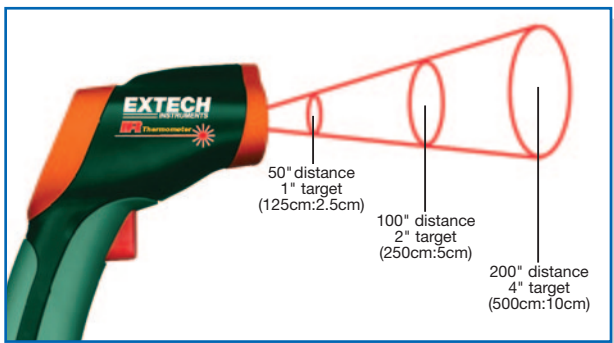

50:1 distance to target ratio

Ordering Information

Part Number **REB30040** Portable IR Thermometer
Part Number **REB32040** Portable IR Thermometer
with NIST Certificate

Standard lead time is stock to 3 weeks.

WARNING: Cancer and Reproductive Harm - www.P65Warnings.ca.gov.

(800) 323-6859 • Email: sales@tempco.com

Non-contact Infrared Temperature Measurement System — NCIT-LC Advanced



The NCIT-LC Advanced is a powerful **two-piece** infrared temperature measurement system with miniature sensing head and separate communications electronics. The sensor is small enough to be installed just about anywhere, yet it outperforms much larger systems.

Available in a rugged cast metal electronics enclosure, the **LC-Advanced** offers a host of advanced signal processing features you won't normally find in sensors costing much more.

Designed for an **endless range of applications**, the **LC-Advanced** features a variety of sensing head options. Low temperature sensors with a measurement range of -40°F to 1832°F (-40°C to 1000°C), fast response (<20 mSec) sensors, and 5 μm spectral response sensors, provide an impressive array of solutions for your process needs.

The **rugged stainless steel sensing head** ensures reliable long term performance in the harshest industrial environments. Although the LC-Advanced sensor is small in size, it has all the performance you need with 1% accuracy, and a **choice of high resolution optics up to 22:1**.

Standard features include adjustable Emissivity, Peak Hold, Valley Hold, and Averaging functions. All sensor parameters are easily adjustable on the built-in user interface keypad, or remotely with the Windows® 7 compatible DataTemp software via the **built-in USB interface**.

Advanced features further extend the power of the **LC-Advanced** and include user configurable alarm output, digital "recipe" table inputs that can be easily interfaced to an external control system, an external reset input for signal processing, and external inputs for analog emissivity adjustment or reflected energy compensation.

Optional RS485, Modbus® or Profibus® network interfaces simplify integration with a factory or machine control system.

The **NCIT-LC Advanced** — a new level of innovation and performance in non-contact temperature measurement!

Design Features

- * Rugged IP65 rated sensing heads survive ambient temperatures to 248°F (120°C) without cooling
- * Precision high resolution optics, up to 22:1
- * Fast response times of < 20 ms
- * Miniature sensing head fits where other sensors can't
- * Intuitive user interface with high resolution LCD display
- * Automatic sensing head detection — plug and play
- * User configurable analog outputs (0/4-20mA, 0-5/10V, type J, K, R or S t/c)
- * Isolated solid state alarm relay output
- * Adjustable Emissivity, Peak Hold, Valley Hold and Averaging functions
- * Standard USB 2.0 digital interface for remote setup

Specifications

Spectral Response:LT (Low Temp.)— 8 to 14 microns
.....G5 (glass)— 5 microns

Optical Resolution: LTS — 2:1, 10:1, 22:1
LTF — 10:1
G5 — 22:1

Temperature Range:
LTS (2:1, 10:1) -40° to 1112°F (-40° to 600°C)
LTF (LTS 22:1) 32° to 1832°F (0° to 1000°C)
G5S 482° to 3002°F (250° to 1650°C)

System Accuracy: ±1% of reading or ±1°C, whichever is greater

Thermocouple Output Accuracy: <1°F (0.5°C)
±1% of reading or ±2.5°C, whichever is greater

System Repeatability: ±0.5% of reading or ±0.5°C (1°F), whichever is greater

Temperature Resolution: LT 0.1°C or 0.2°F

System Response Time: LTS 130ms (90%)
LTF 20ms (90%)
G5 55ms (90%)

Emissivity: 0.100 to 1.100 digitally adjustable increments of .001

Transmission: 0.1 to 1.000 digitally adjustable increments of .001

Signal Processing: Peak hold, valley hold, variable averaging filter, adjustable up to 998 seconds

Non-contact Infrared Temperature Measurement System — NCIT-LC Advanced

Sensor Head Specifications

Environmental Rating: NEMA 4 (IP65)

Head Ambient Temperature Range: 14° to 248°F (-10° to 120°C)

With air cooling up to 392°F (200°C)

Cable Length: 3.3 ft (1m) standard, optional: 9.9 ft (3m), 26 ft (8m), 50 ft. (15m)

Storage Temperature: -4° to 185°F (20° to 85°C)

Relative Humidity: 10 to 90%, non-condensing

Construction: Stainless Steel

Weight with 1 m cable: 1.75 oz. (50g)

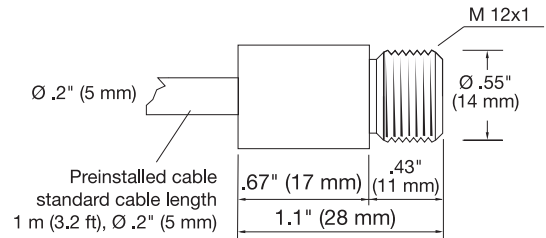

Available Sensor Heads

Part Number	Optics	Sensing Temperature Range	Response Time	Maximum Ambient Temperature	Type	Cable Length	Comments
REN30001	2:1	-40° to 1112°F (-40° to 600°C)	130ms	248°F/120°C	LTS	3.3 ft./1m	General Purpose
REN30002	10:1	-40° to 1112°F (-40° to 600°C)	130ms	248°F/120°C	LTS	3.3 ft./1m	General Purpose
REN30003	22:1	32° to 1832°F (0° to 1000°C)	130ms	248°F/120°C	LTS	3.3 ft./1m	General Purpose
REN30004	10:1	32° to 1832°F (0° to 1000°C)	20ms	248°F/120°C	LTF	3.3 ft./1m	Fast Response
REN30005	10:1	482° to 3002°F (250° to 1650°C)	130ms	248°F/120°C	G5	3.3 ft./1m	5μm sensing for glass applications

The NCIT-LC Advanced Infrared sensor heads can be supplied with the following optional cable lengths:

- 10 ft. / 3m cable
- 26 ft. / 8m cable
- 49 ft. / 15m cable
- 98 ft. / 30m cable

Calibration Certificate with NIST/DKD traceability can be provided. Specify when ordering.

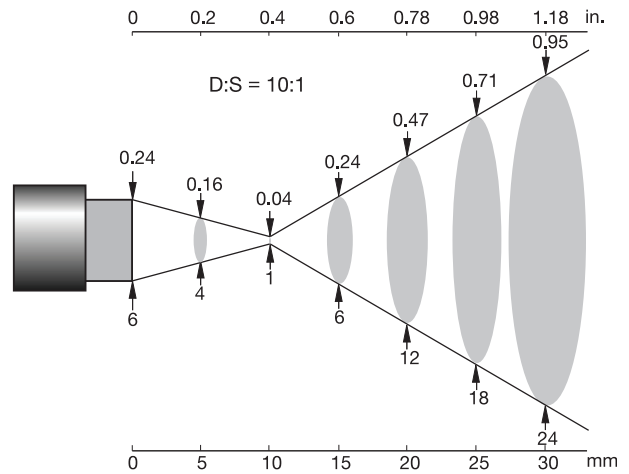

10:1 optics with close focus accessory

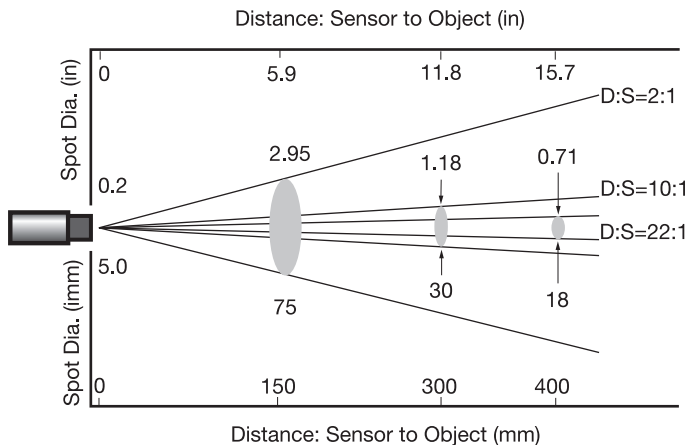

2:1, 10:1 and 22:1 optics

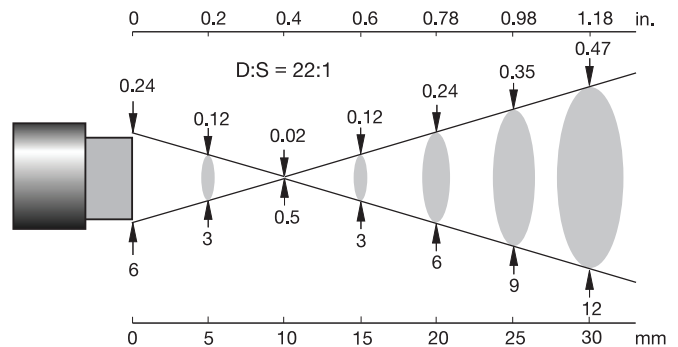

22:1 optics with close focus accessory

CONTINUED 

Non-contact Temperature Measurement

Non-contact Infrared Temperature Measurement System — NCIT-LC Advanced

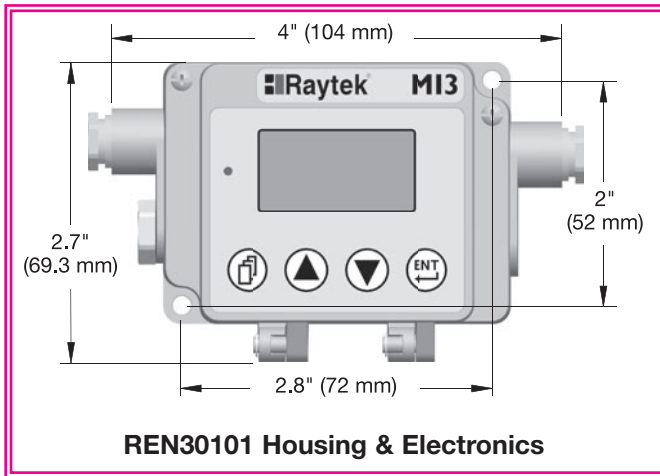

REN30101 NCIT-LC Advanced Electronics and Enclosure Specifications

- Digital Interface:** USB 2.0
(RS485, Modbus® or Profibus® optional)
- Outputs:** Scalable 4-20mA, 0-20mA,
0-10V, 0-5V, J, K, R or S thermocouple
- Inputs:** Digital inputs for emissivity control, ambient background
temperature compensation, trigger/hold input
- Alarm Relay:** 48 VAC, 300 mA optically isolated solid state relay
- Output Impedance (TC output):** 20 ohms
- Minimum Load Impedance:** (mV output): 10K ohms
- Maximum Loop Impedance:** (mV output): 500 ohms
- Power Draw:** 4W max
- Power Supply:** 8-32VDC
- Housing Construction:** Zinc, die cast
- Environmental Rating:** NEMA 4 (IP65)
- Electronics Housing, Max. Temp.:** 14° to 150°F (-10° to 65°C)
- Storage Temperature:** -4° to 185°F (-20 to 85°C)
- Relative Humidity:** 10 to 95%, non-condensing
- Electronics Weight:** 9.5 oz. (270g)

The **REN30101** NCIT-LC Advanced Electronics and Enclosure can also be ordered with the infrared sensor head pre-installed.

Specify which Sensor Head meets your requirements when ordering.

Ordering Information

Select the part numbers of the NCIT-LC Advanced Sensor Head, Electronics/Enclosure and Accessories that meet your requirements.

Standard lead time is stock to 4 weeks.

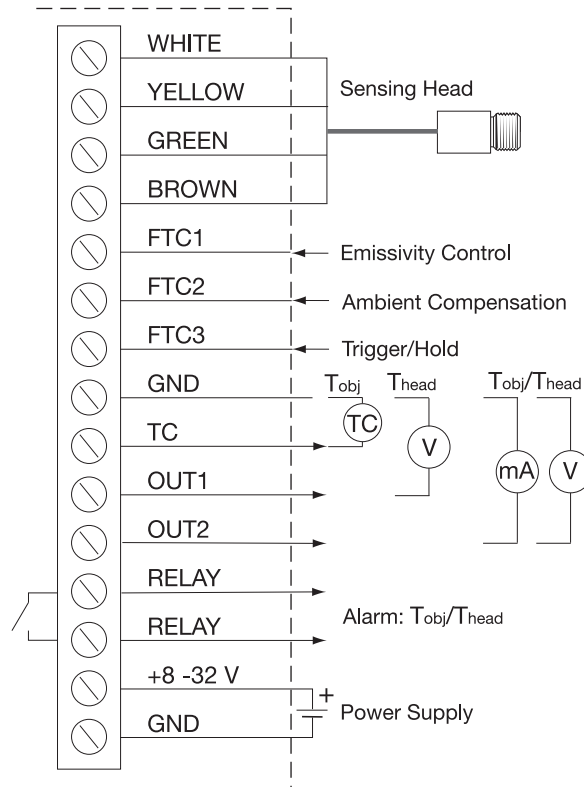

REN30101 NCIT-LC Advanced Electronics Enclosure Terminal Wiring

Accessories

Part Number	Description
REN00309	Close focus lens accessory. 10 mm focus distance.
REN00209	Power supply: 12 Vdc at 200 mA, 120 Vac input
REN00301	Air cooling and purging system with 2.8 ft./8m of hose Maximum ambient temperature: 392°F/200°C
REN00302	Air purge jacket, no cooling
REN00303	Sensing head, adjustable mounting bracket
REN00305	Sensing head, fixed mounting bracket

WARNING: Cancer and Reproductive Harm - www.P65Warnings.ca.gov.

Non-contact Infrared Temperature Measurement System — NCIT-LLC Series



The NCIT - LLC model provides the advantages of infrared temperature measurement in a compact, low cost, integrated sensor. Designed for easy integration with a standard 4-wire system, the CI sensor can easily replace traditional contact probes with a type J or K thermocouple output, or with a 0-5 volt dc output if your application is susceptible to noise or requires a longer cable run.

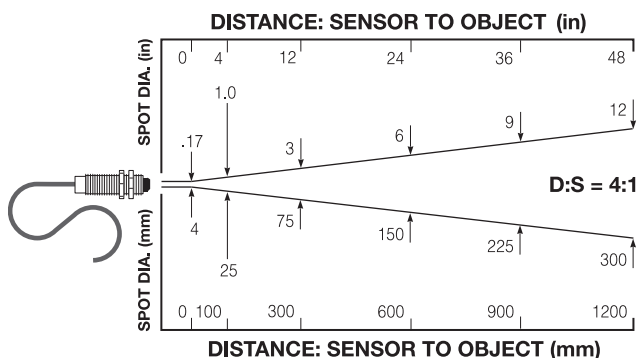
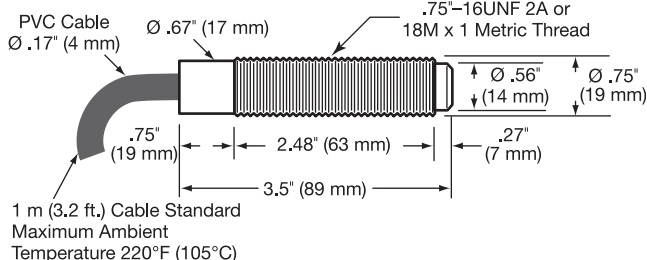

Ordering Code:

REN2 - 1 2 3 4 & 5

Basic assembly includes: sensor with 3/4-16 UNF thread, preinstalled 3.3 ft./1 m cable and two mounting nuts.

Overall Range BOX 1

1 = 32° to 662°F (0° to 350°C)
2 = 86° to 932°F (30° to 500°C)

Output BOX 2

J = Type J thermocouple
K = Type K thermocouple
V = 10mV/°C

Cable Length and Type BOX 3

A = 3.3 ft./1m cable - 220°F/105°C
B = 10 ft./3m cable - 220°F/105°C
C = 50 ft./15m cable - 220°F/105°C
Specify D, E or F if ordering coolable housing
D = 3.3 ft./1m cable - 500°F/260°C
E = 10 ft./3m cable - 500°F/260°C
F = 50 ft./15m cable - 500°F/260°C

Options (Select 2) BOX 4 & 5

C = Coolable housing with air purge
M = 18M x 1 metric thread instead of 3/4-16 UNF
N = None

Ordering Information

Create an ordering code by filling in the boxes per your requirements and a part number will be assigned.

Standard lead time is stock to 4 weeks.

Design Features

- * Type J or K thermocouple, or 0-5 VDC output
- * Two models cover temperature ranges from 32° to 932°F (0° to 932°F)
- * NEMA 4 (IP 65) stainless steel housing
- * 4:1 optics at 90% energy
- * 350 ms response time to 90% energy
- * Powered by 12-24 VDC at 20 mA
- * Accessories for cooling and air purging

Measurement Specifications

Overall Temperature Range: 32° to 662°F (0° to 350°C)

Accuracy: 32° - 240°F (0° - 115°C): ±6°F (±3°C)

241° - 440°F (116° - 225°C): ±5%

441° - 662°F (116° - 225°C): >±5%

Overall Temperature Range: 86° to 932°F (30° to 500°C)

Accuracy: 86° - 211°F (30° - 99°C): ±10°F (±6°C)

212° - 932°F (100° - 500°C): ±2% or ±6°F (3°C)

Spectral Response: 7 to 18 microns

Repeatability: 1% of reading or ±2°F (1°C)

Temperature Resolution: <1°F (0.5°C)

Response Time (95%): 350 ms

Emissivity: Fixed at 0.95

Electrical Specifications

Outputs: Select Type J or K thermocouple or 10 mV / °C

Output Impedance: 50 ohms

Min. Load Impedance: 50K ohms

Power Supply: 12 - 24 Vdc @ 20 mA

Standard Cable Length: 3.2 ft. (1 m)

Sensor Specifications

Environmental Rating: NEMA 4 (IP65)

Ambient Temperature Range: 32° to 160°F (0 to 70°C)

With air cooling 32° to 200°F (0 to 90°C)

With water cooling 32° to 500°F (0 to 260°C)

Thread: 3/4-16 UNF, optional 18M x 1

Storage Temperature: -22° to 185°F (-30 to 85°C)

Relative Humidity: 10 to 90%, non-condensing

Weight: 4.5 oz. (130g)

Accessories

Part Number	Description
REN25001	Fixed Mounting Bracket
REN25002	Adjustable Mounting Bracket
REN25003	Lens Air Purge Collar
REN25004	Right Angle Mirror

WARNING: Cancer and Reproductive Harm - www.P65Warnings.ca.gov.

Non-contact Infrared Temperature Measurement System — NCIT Plus Series



If temperature is a factor in your quality and manufacturing yield, then put this technology to work for you.

Design Features

- * 0° to 1000°F (-18 to 538°C)
- * Compact 1/8 DIN digital monitor with large 4-digit display
- * User-defined thermocouple or 4-20 mA output
- * Universal 110-220 VAC power input
- * Adjustable emissivity at ambient parameters
- * Adjustable dual setpoints and deadband alarm outputs
- * Choice of sensing head to match application
- * Standard and close focus optics available
- * Accessories for cooling and air purging
- * Field interchangeable sensing heads

Common Industrial Applications

- ➔ Plastics
- ➔ Paper & Pulp Converting
- ➔ Chemicals
- ➔ Food Processing
- ➔ Pharmaceutical
- ➔ Electronics
- ➔ Construction
- ➔ Industrial Maintenance

Non-contact Temperature Measurement for Industrial Processes

The NCIT Plus Series is a versatile, two-piece temperature monitoring system that combines a compact, value-priced monitor with an infrared sensing head. The heart of the system is the 1/8 DIN NCIT Plus Monitor which provides advanced infrared processing capabilities including peak and valley hold, averaging, and user-adjustable offset.

Advances in optical and electronic design, originally developed for high-end infrared systems, have been adapted to this low-cost line without compromise in performance when compared to infrared sensors that cost twice as much just a few years ago.

The **NCIT Plus** models can't scratch, tear, smear or contaminate because they don't make contact with your product. They are easier and safer to install and maintain because they can be positioned away from hot and hazardous processes and moving products.

They remain accurate over a longer period of time because they're not subjected to the abuse that a contact device receives. And they deliver much faster response time than contact thermocouples, while rivaling their accuracy and repeatability.

In the long run, non-contact temperature measurement can help you improve quality, speed production, and save money.

1/8 DIN NCIT Plus Monitor

Along with its large 4-digit LED display, the monitor provides a user-defined 4-20mA or thermocouple output. Two adjustable setpoints/deadbands control 5V alarm outputs or optional 3A mechanical relays. The **NCIT Plus Monitor** accepts universal 110-220 Vac power input and provides a 24 Vdc / 50 mA excitation voltage for loop power to external sensors. All monitor functions are configured via the front panel, including °C/°F switching.

The **NCIT Plus Monitor** provides adjustable emissivity and ambient compensation when used with the **NCIT Plus Standard** infrared sensing heads.

Standard Sensing Heads

These high performance, 8-14 micron sensors combine current loop driven signals with high resolution optics.

The **NCIT Plus Standard w/ Laser** sensing head comes equipped with laser sighting for alignment in hard to reach locations, or to small or distant targets. The 50:1 distance to spot (D:S) ratio provides the capability of measuring a spot size of 1.2" at a distance of 5 ft.

The **NCIT Plus Standard** sensing head's D:S ratio of 35:1 allows a spot size of 1.7" at a distance of 5 ft.

Proven Technology

Non-contact infrared temperature sensors have proven advantageous and reliable in many industries for over 25 years. Tempco brings this technology to you at a price competitive with thermocouples.

Non-contact Infrared Temperature Measurement System — NCIT Plus Series

Measurement Specifications

Temperature Range (All Sensor Heads):	0 to 1000°F (-18 to 538°C)
Spectral Response:	Standard & Laser: 8 to 14 μm
Optical Resolution:	Laser: 50:1, close focus 45:1 Standard: 35:1, close focus 30:1
System Accuracy:	$\pm 1\%$ or $\pm 2^\circ\text{F}$ ($\pm 1^\circ\text{C}$), whichever is greater
System Repeatability:	$\pm 0.5\%$ or $\pm 2^\circ\text{F}$ ($\pm 1^\circ\text{C}$), whichever is greater
Response Time – (95% of final reading):	Standard & Laser: 500 ms
Emissivity:	Digitally adjustable, 0.1 to 1.09 by increments of 0.01 steps
Signal Processing:	Peak and valley hold (up to 998 sec, 999 = infinite hold with external reset), Variable averaging filter (up to 60 sec), T-ambient: fixed background ambient temperature compensation

Electrical Specifications

Power Supply:	110 /220 VAC, $\pm 20\%$, 50-60 Hz
Inputs:	User configurable inputs for Laser or Standard sensing heads, any 5-0 Vdc or 4-20 mA sensor, or thermocouple (J, K, E, N, R, S, T) External reset input to reset peak/valley hold
Outputs-Signal:	4-digit, LED display, $^\circ\text{F}/^\circ\text{C}$ selectable. User configurable 4-20 mA current or thermocouple output (J, K, E, N, R, S, T)
Alarm Output:	Two adjustable setpoints with deadbands controlling +5 Vdc alarm outputs or optional 3A mechanical relays
DC Supply Output:	24 Vdc / 50 mA excitation voltage for powering external sensors

Sensor Specifications

Environmental Rating:	Monitor Front Panel: NEMA 12 (IP54) Laser/Standard Head: NEMA 12 (IP65)
Ambient Temperature:	32° to 120°F (0 to 50°C) 32° to 150°F (0 to 65°C) laser shuts off automatically at 120°F (50°C)
Monitor	32° to 120°F (0 to 50°C)
Laser/Standard Head	32° to 150°F (0 to 65°C)
With water cooling	32° to 350°F (0 to 177°C)
With air cooling	32° to 250°F (0 to 120°C)
Relative Humidity:	10 to 95%, non-condensing
Monitor Dimensions:	1/8 DIN, 96 × 48 × 120 mm 1.9" × 3.78" × 4.75"
Cutout Dimensions:	1.75" × 3.63" (92 × 44 mm)
Weight:	Monitor: 320g (0.7 lb.)

Distance to Spot Ratio—Standard

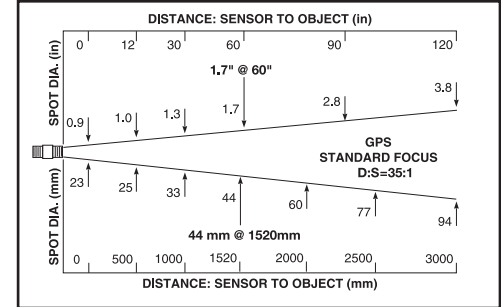

Distance to Spot Ratio—Standard Close Focus

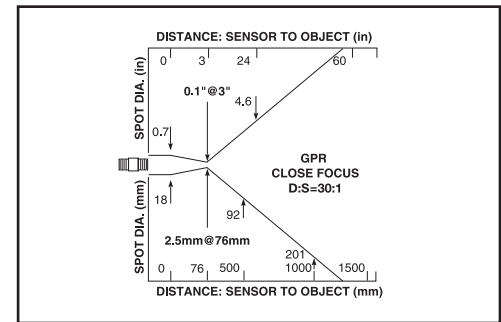

Distance to Spot Ratio—Laser

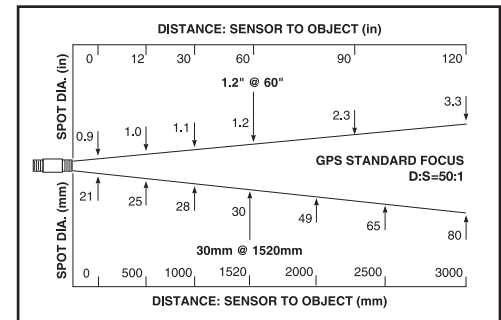

Distance to Spot Ratio—Laser Close Focus

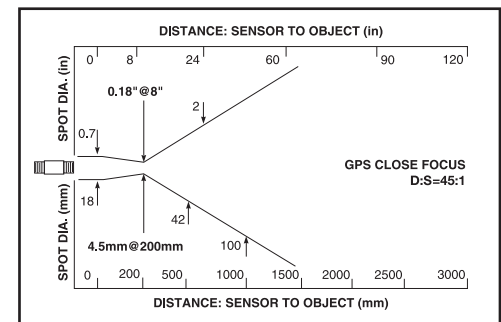

Infrared Temperature Measurement — NCIT Plus Series

NCIT Plus Monitor

- REN01001** 1/8 DIN Panel Meter 110/220VAC
w/ 5 Vdc alarm outputs
- REN01003** 1/8 DIN Panel Meter 110/220VAC
with optional 3A relays for alarm outputs
- REN01002** Light duty aluminum mounting bracket to allow
for sub-panel mounting

NCIT Plus Standard Sensing Heads (includes mounting bracket and nut)

- REN01101** Standard focus infrared sensing head, 35:1 optics
- REN01102** Standard – close focus infrared sensing head,
30:1 optics
- REN01120** NIST/DKD calibration certificate (also for
water cooled) **Must be ordered with unit.**

With Water Cooled Housing and Lens Air Purge Collar

- REN01110** Standard focus infrared sensing head
- REN01111** Standard – close focus infrared sensing head

NCIT Plus Standard with Laser Sight Sensing Heads

(includes an adjustable mounting bracket and nut,
13 ft. (4m) cable for between the sensor and the
laser switch box, and 26 ft. (8m) cable to connect
the laser switch box to the NCIT Plus Monitor)

- REN01103** Standard focus infrared sensing head, 50:1 optics
- REN01104** Standard – close focus infrared sensing head,
45:1 optics
- REN01121** NIST/DKD calibration certificate (also for
water cooled) **Must be ordered with unit.**

With Water Cooled Housing and Lens Air Purge Collar

- REN01112** Standard focus infrared sensing head
- REN01113** Standard – close focus infrared sensing head

Air/Water Cooled Sensing Head

The Air/Water-Cooled Housing option allows the laser or standard sensor to be used in ambient temperatures **up to 250°F (121°C) with air cooling**, or **350°F (177°C) with water cooling**. It is supplied with two 1/8" NPT brass fittings.

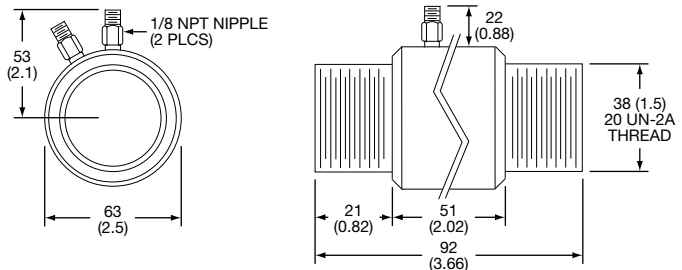

Air flow at 77°F (25°C) should be **3 to 5 cfm** (1.4 to 2.4 liters/sec) with a pressure drop across the housing of 2 to 5 PSIG (0.14 to 0.35 kg/cm²). Water flow should be approximately **0.5 gallons (2 liters) per minute**; water temperature should be 50 to 80°F (10 to 27°C) for efficient cooling.

All units ordered with the Air/Water-Cooled Housing include the Air Purge Collar to avoid condensation and lens damage.



Note: The laser-equipped standard sensing head is 125 mm (4.92") long. The laser shuts off automatically at 120°F (50°C).

Standard / Laser Sensing Heads

All Standard sensors are supplied with a fixed bracket and a mounting nut. Alternatively, the sensor may be mounted through a hole, on a customer-supplied bracket, with the pipe adapter, or with other accessories. Avoid installing the sensor cable in noisy electrical environments. In this environment, it is recommended to install the cable in conduit. A conduit adapter accessory is available for this purpose.



Note: The laser-equipped standard sensing head is 125 mm (4.92") long.

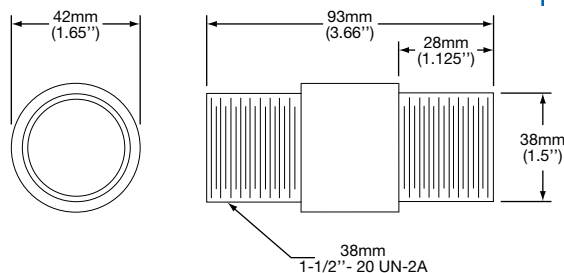

Infrared Temperature Measurement — NCIT Plus Series Accessories

Pipe Adapter:

The Pipe Adapter is used to connect the Standard or Laser Head to a 1.5 inch NPT pipe thread.

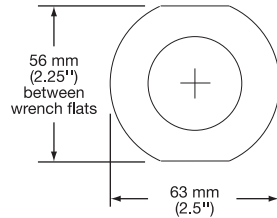

REN00206

Conduit Adapter

The Pipe Adapter is used to connect the Standard or Laser Head to a 1/2-inch NPT conduit fitting.

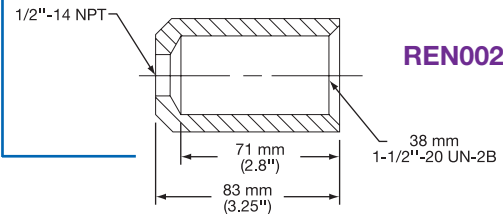

REN00205

Lens Air Purge Collar:

The Air Purge Collar accessory is used to keep dust, moisture, airborne particles and vapors away from the lens. It may be installed before or after the bracket. Air flow should be a maximum of 1-3 cfm (0.5-1.5 liters/sec). Clean or "instrument" air is recommended to avoid contaminants from settling on the lens.

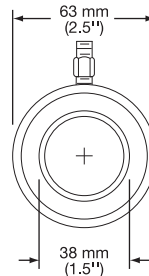

REN00204

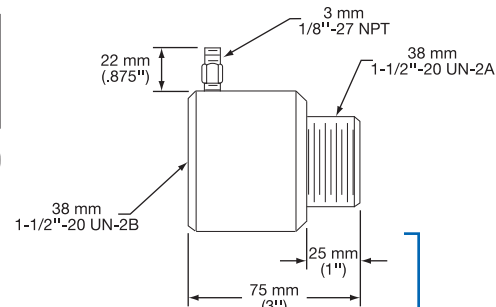

NCIT Plus Standard Sensing Head Cables

5 conductor cables for connecting the standard sensing head to the panel meter.

REN01201	13 ft. (4m) – Regular temperature
REN01202	13 ft. (4m) – High temperature for Air/Water cooled Sensing Head
REN01203	26 ft. (8m) – Regular temperature
REN01204	26 ft. (8m) – High temperature for Air/Water cooled Sensing Head

Additional Accessories

REN00208	Fixed mounting bracket for the regular sensing head
REN00213	Adjustable mounting bracket for the regular sensing head
REN00207	Mounting nut

Used in conjunction with the Standard or Laser Sensing Head.

Ordering Information

Choose the **NCIT Plus, accessories, and/or options** desired, and order by the associated part number.

Standard lead time is stock to 3 weeks.

⚠ WARNING: Cancer and Reproductive Harm - www.P65Warnings.ca.gov.